



# CONTEG DATA SHEET

version: 10-02-2011

TOTAL SOLUTIONS FOR DATA CENTERS

## MODULAR CONTAINED AISLE

### CONTEG, spol. s r.o.

Headquarters Czech Republic:  
Na Vítězné pláni 1719/4  
140 00 Prague 4

Tel.: +420 261 219 182  
Fax: +420 261 219 192  
[conteg@conteg.com](mailto:conteg@conteg.com)  
[www.conteg.com](http://www.conteg.com)

### Local Offices:

Austria:	+43 699 1819 7071
Benelux:	+32 477 957 126
Eastern Europe:	+49 172 848 4346
France:	+33 686 074 386
Germany:	+49 170 523 4958
Russia:	+7 495 967 3840



*Cabinets from different manufacturers of varying heights, widths and depths are added to existing installations without any consideration that one day might be required to roof the area that is being supplied by cooled air. Modular Contained Aisle for traditional hot/cold aisle layouts is the right containment solution when higher cooling efficiency is needed, but the rack infrastructure cannot be changed and fitting the standard contained aisle is limited for any reason.*

Modular Contained Aisle can be applied in almost all existing data centers which use standard Hot/Cold layout. This solution is applicable on:

- Racks or other IT equipment of any vendor with any dimension (up to the height of 2350mm)
- Rows of racks with gaps (missing racks in the row)
- Hot/Cold aisles with width up to 1200mm and 1800mm

**MAIN BENEFITS:**

- Reduction of hot and cold air mixing by eliminating cold air by-passes
- Solution does not require equipment shut down to retro-fit in operating data centers
- Product allows achieving lower air inlet temperatures to IT equipment
- Product allows higher return air temperature to CRAC units that result in an increase of net sensible cooling capacities
- Product provides balanced air distribution along the entire rack elevation, due to this the equipment in higher sections of the cabinets is cooled more effectively
- Increase of energy efficiency - regardless of the room size or number of installed racks
- Self-supporting frame construction together with PVC blinds (can be easily cut off to the required length) = stability and modularity

**DESCRIPTION:**

- Solution available for all IT and other equipment up to 2350mm (up to 48U racks), minimal requested ceiling height is 2600mm
- Ready to cover aisles up to 1200mm or 1800mm wide
- Fixed and adjustable top sections to adapt the solution to the aisle on any length
- Top sections made of transparent, fire retardant Polycarbonate materials
- Hollow or clear polycarbonate available-both sides
- PVC blinds made of transparent fire retardant PVC anti-static material
- Available in version with double doors as well as with PVC blinds instead of doors
- Frame and supporting sections made of powder coated sheet steel



::modular contained aisle

**MODULAR CONTAINED AISLE - PARTS**

Code	Description
<b>DOOR SECTION</b>	
CA-MDS-120B	Door section with PVC blinds, with 120mm
CA-MDS-120D	Door section with double door, with 1200mm
CA-MDS-180B	Door section with PVC blinds, with 120mm
CA-MDS-180D	Door section with double door, with 1200mm
<b>ROOF SECTION - HOLLOW POLYCARBONATE</b>	
CA-MRS-90	Top cover without side section, hollow polykarbonate (slightly opaque), 900mm lenght, fix, width of aisle 1200mm, RAL 7035 or 9005
CA-MRS-90A	Top cover without side section, hollow polykarbonate (slightly opaque), range of the lenght 20-880mm, width of aisle 1200mm, RAL 7035 or 9005
CA-MRS-90/180	Top cover without side section, hollow polykarbonate (slightly opaque), 900mm lenght, width of aisle 1800mm, fix, RAL 7035 or 9005
CA-MRS-90A/180	Top cover without side section, hollow polykarbonate (slightly opaque), width of aisle 1800mm, range of the lenght 20-880mm, RAL 7 035 or 9005
<b>ROOF SECTION - CLEAR POLYCARBONATE</b>	
CA-MRSC-90	Top cover without side section, clear polykarbonate, 900mm lenght, fix, width of aisle 1200mm, RAL 7035 or 9005
CA-MRSC-90A	Top cover without side section, clear polykarbonate, range of the lenght 20-880mm, width of aisle 1200mm, RAL 7035 or 9005
<b>SIDE SECTION (package for one sideof roof section including support system)</b>	
CA-MSS-55	Side blinds for CA-MRS or CA-MRSC – one side. Length 550 mm (for racks height 42U or 1980mm or higher), with support bracket (threaded rod and bracket for fixing on the rack)
CA-MSS-95	Side blinds for CA-MRS or CA-MRSC – one side. Length 950 mm (for racks height 33U or 1580mm or higher), with support bracket (threaded rod and bracket for fixing on the rack)
CA-MSS-250B	Blinds for CA-MRS or CA-MRSC – one side. Length 2500 mm (for gap between racks, at the floor), with support column



### Door section with blinds

- Self-supporting door frame, base of columns comprises holes for anchoring screws (screws are not part of delivery)
- PVC blinds are used to seal the door space, length 2500mm; blinds are transparent, fire retardant, made of PVC anti-static materials compliant with EN ISO 13501-1 for all PVC parts
- Brush used to seal the space between door frame and rack
- Compatible with all CONTEG racks – if lateral rack of the aisle is CONTEG PREMIUM or OPTIMAL rack, we recommend to connect the frame to the rack using DP-DR-UNI (ordered separately)
- Possible to use for almost any type of rack, CRAC/CRAH or other IT equipment of any vendors – no connection to the rack is needed due to the section's self-supporting construction
- Can be combined with door section with double door on opposite side
- Two sizes for aisles width 1200 and 1800mm

Note: double door provide better efficiency of sealing than blind strips

Code	Dimensions including packing in mm			Gross weight in kg
	H	W	D	
CA-MDS-120B	140	495	2510	44
CA-MDS-180B	140	495	2510	56



### Door section with double door

- Self-supporting door frame, base of columns comprises holes for anchoring screws (screws are not part of delivery)
- Door section contains frame for double door fitting
- Double door part of delivery
- Brush used to seal the space between door frame and rack
- Compatible with all CONTEG racks – if lateral rack of the aisle is CONTEG PREMIUM or OPTIMAL rack, we recommend to connect the frame to the rack using DP-DR-UNI (ordered separately)
- Possible to use for almost any type of rack, CRAC/CRAH or other IT equipment of any vendors – no connection to the rack is needed due to the section's self-supporting construction
- Can be combined with door section with blinds on opposite side
- Two sizes for aisles width 1200 and 1800mm (for 1800 mm with infill panel and extension kits)

Note: double door provide better efficiency of sealing than blind strips

Code	Dimensions including packing in mm			Gross weight in kg
	H	W	D	
CA-MDS-120D	for more information contact			
CA-MDS-180D	our product department			



### Top section with fixed size

- Hollow polycarbonate panel (CA-MRS-90, CA-MRS-90/180)
  - Transmittance 82%
  - Light-weight
  - Easy cleaning
- Clear polycarbonate panel (CA-MRSC-90)
  - Transmittance 100%
  - Heavy-weight
  - Please note, that clear polycarbonate is prone to scratches
- Top part of the modular contained aisle
- Fixed length 900mm
- For modular contained aisle width 1200mm and 1800mm (only hollow polycarbonate panel)
- Minimally two top sections with fixed size per modular contained aisle required
- Drilling on site possible - enable to lead sprinklers of fire suspension system through the panel into the space of contained aisle
- Can be connected with the adjacent door or other top section (fixed as well as adjustable)
- Section is compatible with PVC blinds of any length (ordered separately)
- Ready to accept supporting elements (supporting element is part of delivery of PVC blinds)

Code	Dimensions including packing in mm			Gross weight in kg
	H	W	D	
CA-MRS-90	80	870	1305	10
CA-MRS-90/180	80	870	1905	15
CA-MRSC-90	80	870	1305	16

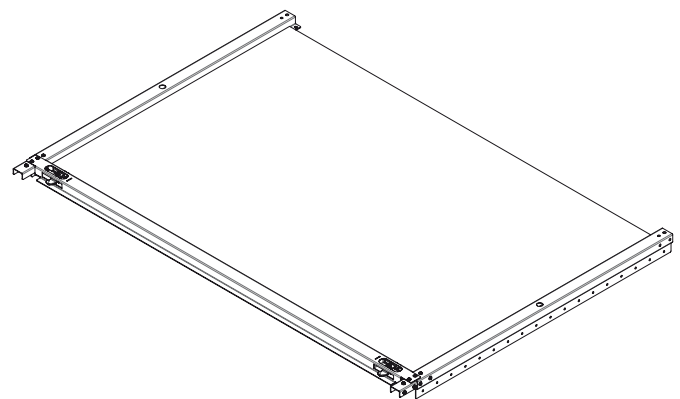



**Top section with adjustable size**

- Hollow polycarbonate panel (CA-MRS-90A, CA-MRSC-90A/180)
  - Transmittance 82%
  - Light-weight
  - Easy cleaning
- Clear polycarbonate panel (CA-MRSC-90A)
  - Transmittance 100%
  - Heavy-weight
  - Please note, that clear polycarbonate is prone to scratches
- Top part of the modular contained aisle
  - Length range from 20 to 880mm, fluent sliding
  - For modular contained aisle width 1200mm and 1800mm (only hollow polycarbonate panel)
  - One top section with adjustable size per modular contained aisle required
  - Drilling on site possible - enable to lead sprinklers of fire suspension system through the panel into the space of contained aisle
  - Can be connected with the adjacent fixed size top sections only
  - Section is compatible with PVC blinds of any length (ordered separately)
  - Ready to accept supporting elements (supporting element is part of delivery of PVC blinds)
- Always need to be use one piece on one aisle

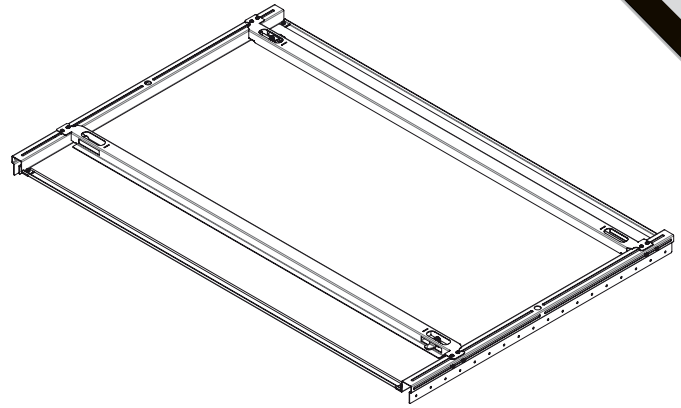

Code	Dimensions including packing in mm			Gross weight in kg
	H	W	D	
CA-MRS-90A	80	870	1305	13
CA-MRS-90A/180	80	870	1905	18
CA-MRSC-90A	80	870	1305	19

**PVC blinds - CA-MSS-55, CA-MSS-95, CA-MSS-250B**

- Three different types of PVC blinds:
  - length 550mm for the racks height 42U (1980mm) or higher (CA-MSS-55)
  - length 950mm for the racks height 33U (1580mm) or higher (CA-MSS-95)
  - length 2500mm for the gap between two racks (CA-MSS-250B)
- Made of transparent, fire retardant, PVC anti-static material compliant with EN ISO 13501-1
- All types of blinds can be easily cut off to the required length and shape
- One set of blinds required for each side of any (fixed or adjustable) section - designed for 40% overlap of neighboring blinds
- Set of blinds contains an appropriate supporting element (type and length of supporting element depends on length of blinds)
- Supporting element can be placed on the top part of the equipment and fixate.
- Fixation can be enhanced by a screw or glue
- Compatible with ALL top sections

Code	Dimensions including packing in mm			Gross weight in kg
	H	W	D	
CA-MSS-55	50	210	960	4
CA-MSS-95	50	210	960	4
CA-MSS-250B	110	210	2490	13



::modular contained aisle

**EXAMPLE OF CONFIGURATIONS**

	Aisle 1200mm - length 5m, standard 42U racks	Aisle 1200mm - length 8m, standard 42U racks	Aisle 1200mm - length 8m, mixed racks 42U and 33U racks (half to half)	Aisle 1200mm - length 8m, racks 42U and missing 3 racks	Aisle 1800mm - length 8m, standard 42U racks	Aisle 1800mm - length 8m, mixed racks 42U and 33U racks (half to half)
CA-MDS-120B	2	2	2	2		
CA-MRS-90	5	8	8	8		
CA-MRS-90A	1	1	1	1		
CA-MSS-55	12	18	9	15	18	9
CA-MSS-95			9			9
CA-MSS-250B				3		
CA-MDS-180B					2	2
CA-MRS-90/180					8	8
CA-MRS-90A/180					1	1